

Flourescence attachment and Filters

Fluorescent attachment (above) is an optional accessory for the Universal microscope. Taking off the attachment (above left), shows its five position nosepiece turret. Its top view (middle left) shows the dovetail interface to the microscope. Various beamsplitters inside the fluorescent slider can be seen (left) switched together with emission filters to select various wavelengths.



Transmission filters (below), that swing in and out by push buttons, placed at the right bottom side of the microscope. They accept standard 32 mm filters for contrast enhancement.



Zeiss Universal continued

More details on Zeiss Universal microscope if you are curious about the film magazine, and the Fluorescent filter housing. Here are the instructions to replace filters, and how the Emission, and Absorption sliders are oriented with respect to the beamsplitter block, shown in section drawing view below.

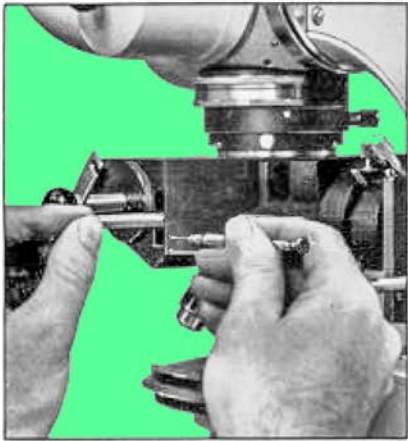
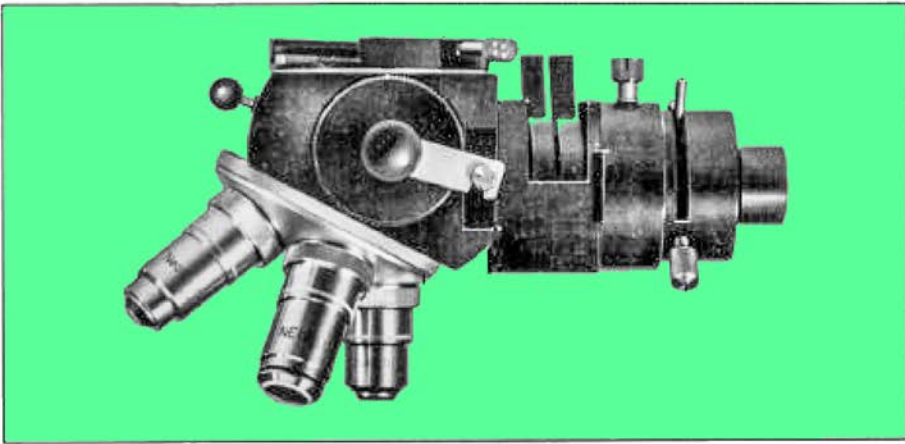

Emission filter slider

Loading of film, see below for details



Beamsplitter Slider

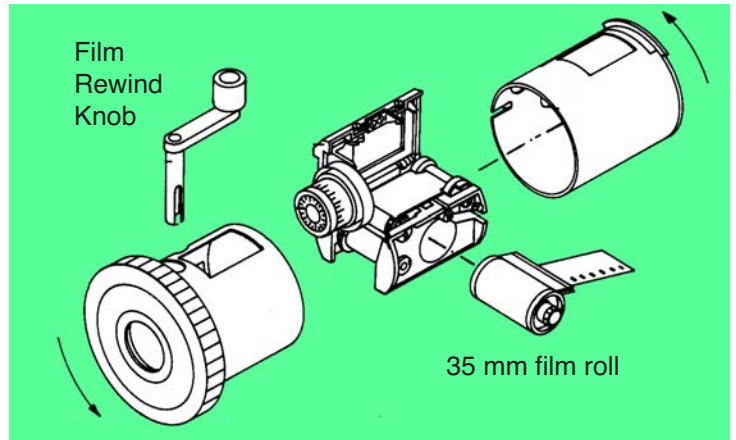
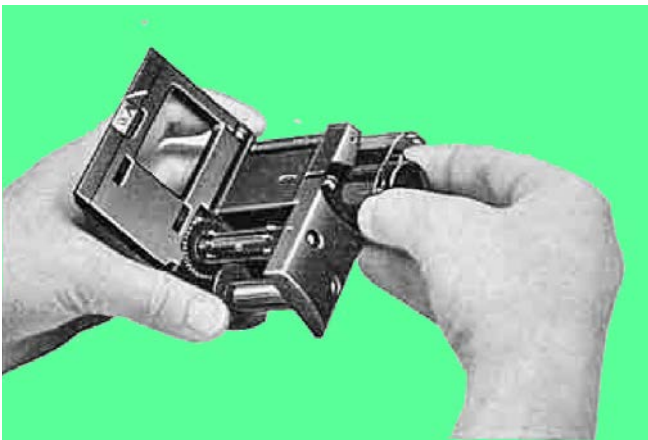
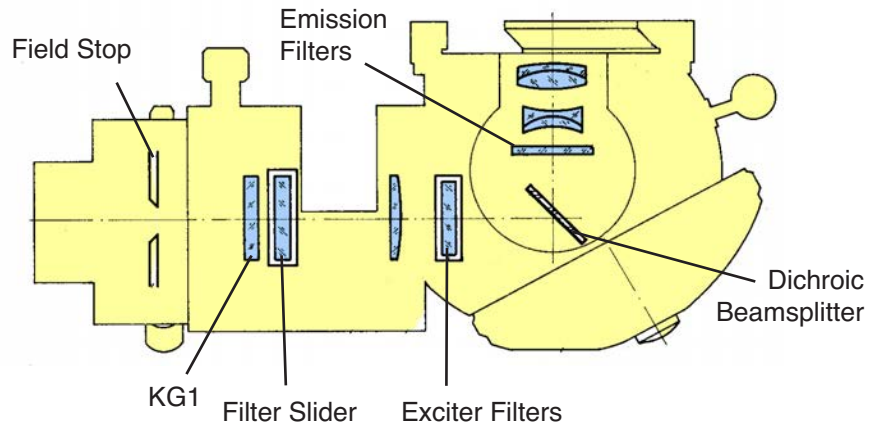

Zeiss Universal Photomicroscope: Here's the 35 mm film being loaded onto the film cartridge insert that goes into the middle section of microscope's main body to record images.